

By Fax/Camp Bag

ELECTION COMMISSION OF INDIA

NIRVACHAN SADAN, ASHOKA ROAD, NEW DELHI-110001

No.51/8/7/2012-EMS

Dated: 19th January, 2012

To

The Chief Electoral Officers of

1. Goa, Panaji
2. Manipur, Imphal
3. Punjab, Chandigarh
4. Uttarakhand, Dehradun
5. Uttar Pradesh, Lucknow

Subject: Comprehensive instructions on use of EVMs after first level checking of EVMs (FLC) -regarding.

Sir,

Instructions with respect of EVMs have been issued from time to time. Instructions to be followed for use of EVMs after the completion of FLC till the counting is over have been consolidated for the convenience of all concerned. Consolidated instructions are given below for strict compliance: -

1. First Randomization of EVMs –

1.1. Process of First Randomization - First randomization of Ballot Units (BUs) and Control Units (CUs) will be done to randomly assign EVMs to Assembly Constituencies (ACs), training and Awareness Programmes. After FLC is over the DEO will fix a schedule for first randomization of EVMs. This schedule should be fixed in such a manner that first randomization is completed before the start of training of polling personnel. During first randomization CUs and BUs are assigned to ACs in the presence of the representatives of recognized political parties. The randomization will be done in such a way that the CUs and BUs are randomly selected by grouping them to match the poll day requirement including the reserve required for each constituency. Surplus CUs and BUs after assigning ACs to them shall also be randomly grouped and distributed AC wise for the purpose of training and awareness programmes. (for the training of the polling staff as well as for the purpose of voter awareness). A sticker of Green colour shall be affixed on the CUs and BUs assigned to ACs for polling. A sticker of Yellow colour shall be affixed on the CUs and BUs assigned for training and

awareness programmes. The sticker shall clearly indicate the Name of State/UT and the Number and Name of Assembly Constituency. “Training/Awareness” will be written on the sticker of CUs and BUs assigned for training and awareness. “Election” will be written on the sticker of CUs and BUs assigned for polling. No current ID will be given during randomization. After randomization the CUs and BUs will be marked “Election” or “Training/Awareness” in the EVM tracking software.

1.2. Communication of the List of Randomized CUs and BUs to Political Parties – After first randomization list of randomized CUs and BUs clearly indicating which CUs and BUs are to be used in which AC for polling and which CUs and BUs are to be used in which AC for training and awareness should be given to each recognized political party and a written acknowledgement obtained. A copy of this list should be given to all the candidates after the last date of withdrawal of candidatures.

1.3. After first randomization the R.O of the constituency, shall take charge of the CUs and BUs randomly allotted to his constituency. The CUs and BUs meant for use at the election shall be separately taken to R.O’s strong room under proper escort and will be guarded 24X7. The training EVMs shall be distributed to the relevant officers for the training purpose. At the time of sealing the strong room, the representatives of political parties can remain present and they can also affix their seal on the lock.

2. Second Randomization of EVMs –

2.1. Second randomization of EVMs has to be done before preparation of EVMs for poll by candidate setting as the address tag of EVM is sealed at the time of preparation of EVM (Candidate Set). The purpose of second randomization of EVMs is to allocate EVMs randomly to polling stations. The Returning officer should fix the date of preparation of EVMs for poll (Candidate set) and intimate all candidates to remain present or send their representatives during the process. The date should be fixed as early as possible after the last date of withdrawal of candidatures and finalization of ballot papers. On this day second randomization should be done before doing the process of preparation of EVMs for polls and CUs and BUs should be randomly allocated to polling stations. After second randomization Polling Station number should be marked in the EVM tracking software, against those BUs and CUs which have been assigned polling stations. Those BUs and CUs which have not been assigned polling stations but are meant to be used in elections should be marked “Reserve” in the EVM tracking software. A list of CUs and BUs along with the number of polling stations assigned to them

should be given to all the candidates. Similarly a list of CUs and BUs kept in reserve should also be given to the candidates and written acknowledgement taken.

2.2. Where more than one Ballot Unit is being used, the Chief Electoral Officers will ensure that the additional prepared Ballot Unit is also allocated randomly to the polling stations. For this purpose there may be two Scenarios –

2.2.1. Scenario 1- Preparation of EVMs and second level randomization is already over before the additional Ballot Units reaches the Returning Officers' Headquarters. In this case another randomization for allocating Ballot Units No.2/3 will be done to allocate the Ballot Units to the polling stations and the list of such allocation may be supplied to the Political Parties/Candidates.

2.2.2. Scenario 2- Preparation of EVMs and second level randomization is done after the arrival of additional Ballot Units. In such case the randomization will be done in such a way that against the polling stations number the Control Units number is shown first and then the Ballot Unit No.1 and Ballot Unit No2 and so on.

2.3. In the constituencies where additional Ballot Units are being used for having the number of contesting candidates more than 16, the Presiding Officers should be specifically instructed to arrange the Ballot Units in the manner as shown in the figure enclosed herewith (Annexure-1). For this purpose the size of Voting Compartment should be increased proportionality in such a way that the electors are not put to any kind of inconvenience and at the same time the secrecy of ballot is not compromised in any way.

3. Preparation of EVMs (Candidate Set) –

3.1. Preparation of EVMs for elections shall be done invariably in the presence of representatives of candidates. The Returning Officer shall draw a schedule for preparation of EVMs. Preparation of EVM should start as soon as possible after the last date of withdrawal of candidatures. Sufficient time should be provided for preparation of EVMs for each Assembly Constituency in the case of Assembly Elections and for each assembly segment in the case of Parliamentary Elections. It may be noted that the time required for preparation of EVM under the new instructions will be sufficiently more than the time required earlier. Therefore, the schedule should be fixed in such a manner that preparation of EVM is not done in a hurried manner. Ideally, the Returning Officer should fix between 3-5 days for each assembly segment for this purpose. In case of Parliamentary Elections, preparation of EVM for assembly segment should be supervised by Assistant Returning Officers. The schedule should be made in such a manner that preparation of EVMs is done for all the assembly segments in separate halls and is

completed at least 8 – 10 days before the poll. Candidates should be informed in writing of the schedule for preparation of EVMs and should be requested to be present or send their representatives at the time of preparation of EVMs. On the day of the preparation, a register in Annexure-2 will be kept by the Returning Officer in which the signature of candidates or their representatives will be taken as token of their presence.

3.2. Arrangements in the premises of preparation of EVM - Preparation shall be carried out in a large hall which can accommodate all EVMs to be prepared. The hall should be able to accommodate officers nominated by the District Election Officer, engineers of Bharat Electronics Limited (BEL) and Electronics Corporation of India Limited (ECIL) and also representatives of candidates. Before the hall is used for preparation, it shall be fully sanitized to ensure that the hall is free from any other electronic device or components of electronic devices. Every entry to the hall shall be guarded by police force. Every hall shall have a door-frame metal detector. Every person who enters the hall shall be frisked at every entry. Entry to this hall shall be on production of Identity Card of the authorized officials/passes issued by the District Election Officer (DEO). Nobody will be allowed to carry any electronic device inside the hall including cell phones, camera and spy pens. Similarly, nobody will be allowed to carry anything out of the preparation hall.

3.3. Manpower for preparation - Only the authorized engineers of BEL and ECIL shall be associated with the preparation of EVMs. BEL and ECIL shall be fully responsible for integrity, efficiency and competence of their engineers. List of engineers deputed by BEL and ECIL for carrying out task during the preparation of EVM in a district along with their identity card numbers etc. shall be communicated in writing by BEL and ECIL to the DEO. No engineers, technicians or other technical staff except authorized engineers/technical staff of BEL and ECIL shall be allowed to enter the preparation hall. Authorized persons will be allowed to enter the preparation hall only after proper identification using photo identity documents. It may be noted that a separate team will be required for each EVM in which 1000 votes are cast during mock poll because the time required for casting of 1000 votes will be at least 4 hours.

3.4. Additional tasks during preparation - Detailed instructions of the tasks to be done during preparation of EVMs have been given in the letters referred in the Commission's letters No. 51/8/7/2007-PLN-IV, dated 12/10/2007, No.464/OBS/EVM/2007 PLN-IV, dated 12/10/2007 & No.51/8/7/2008-EMS (Inst.-I), dated 11/8/2008. In addition to these tasks, following additional tasks shall be performed: -

3.4.1. Checking of Balloting Units (BUs) – Outer cover of BUs shall be opened and inside of BU shown to candidates and their representatives at the time of preparation of EVMs. BU shall be examined by BEL and ECIL engineers who will certify as in Annexure-3 that all components of BUs are original. If any BU is found defective, it will be kept aside and can be taken back to the factory of BEL and ECIL for repairs. No repairs shall be carried out in the field. Changing of components in the field is strictly prohibited. Detailed instructions of checking of BU shall be issued separately by BEL and ECIL for their respective machines. These instructions will include a list of equipment which the engineers will be required to carry within the preparation hall. Security personnel will not allow any other equipment to be carried into the preparation hall.

3.4.2. Conduct of Mock Poll: Casting of votes against all 16 candidate switches, observation of result & clearing of mock poll data will be done for each EVM. In 10 % (ten percent) of EVMs at least 1000 votes shall be polled during the mock poll. In rest of the machines number of votes polled during the mock poll should be to the satisfaction of the representatives of candidates. Representatives of candidates shall be allowed to do the mock poll themselves. Signature of representatives of candidates shall be taken in a register in Annexure –4 as a token of having done mock poll themselves. It may be ensured that the pink paper seal of the CU which has been applied on the CU at the time of FLC is not damaged in any manner in this process.

3.4.3. Demonstration of printout of results: A printout of the results of mock poll as well as a sequential print out of every vote polled during the mock poll shall be taken out for at least 10% of EVMs and shown to the representatives of political parties. Representatives of candidates shall be allowed to pick machines randomly for this purpose. Signatures of representatives of candidates shall be taken in a register in Annexure- 5 as a token of having seen the print out and confirm that there is no discrepancy between the votes polled during the mock poll and results in the print out.

3.4.4. Sealing of plastic cabinet of BU with pink paper seal - Detailed instructions of BU with thread seals already exists. Those instructions shall be followed. **In addition, the BU shall be sealed with a special “pink paper seal” supplied by India Security Press, Nasik, in the presence of candidates or their representatives at the time of preparation of EVMs.** Pink paper seal shall be fixed at the lower most portion of the BU in such a manner that no candidate’s button or candidate’s name or symbol is hidden by the seal. After affixing

the pink paper seal, BEL and ECIL engineer shall put his signature on the pink paper seal. Candidates or their representatives shall also be allowed to put their signatures on the pink paper seal with name of the candidate, party before the signature. Candidates and their representatives should also be allowed to note down the serial number of the pink paper seal on the CU. A register in Annexure - 6 shall be maintained to note down the serial no. of the pink paper seal used on the ballot unit by clearly mentioning unique ID of the BU and pink paper seal no. Signatures of candidates and their representatives will also be obtained on this register. Photocopies of this register will be given free of cost to all candidates once preparation is over.

3.4.5. Supervision of the preparation: Preparation shall be supervised either personally by the RO or one of the AROs deputed by the RO for this purpose. The process of preparation of EVM should be fully video-graphed.

4. Mock Poll on the day of Poll - In order to ensure that the mock poll serves the intended purpose, the Commission directs that-

4.1. Mock poll shall be conducted normally one hour before the scheduled hour of commencement of poll. All contesting candidates should be informed in writing well in advance that mock poll would start one hour before the commencement of poll and they should be advised to instruct their polling agents to be present in time for the mock poll. Polling agents of at least two candidates should be present at the time of Mock Poll. However, if polling agents of at least two candidates are not present, the Presiding Officer may wait for 15 more minutes before conducting the mock poll and if the agents still do not come, then the Presiding Officer may go ahead and start the mock poll. It is further clarified that after waiting for 15 minutes, there is a possibility that only one Polling agent may be present, in that situation also, the Presiding Officer should go ahead and start mock poll. In such case, there should be specific mention in the mock poll certificate on this aspect.

4.2. During the Mock poll, the Ballot Unit (s) should be placed in the Voting Compartment and Control Unit on the table of the Presiding/Polling Officer who will operate the Control Unit. At least two polling officers with the polling agents should be present in the Voting Compartment to watch the polling agents operating on the Ballot Unit, and to keep a record of the votes cast and tally the polled votes.

4.3. The mock poll should be conducted with the polling agents voting at random for each of the contesting candidates. A total of at least 100 votes should be polled in the mock poll. In the case of absence of polling agents of any of the candidates, one of the polling officers or other

polling agents may record the votes for such candidates. The polling officers present in the Voting Compartment should ensure that votes are recorded for each of the contesting candidates. After recording of the minimum of 100 votes, the Presiding Officer will ascertain the result in the Control Unit in the presence of the Polling agents and confirm that the result is tallying with the votes polled in respect of each candidate. Thereafter, Presiding Officer will prepare and sign the mock poll certificate in the prescribed format as in Annexure -7 where pre-2006 EVMs are being used.

4.4. The Presiding Officers shall ensure that the data of the mock poll is deleted, without fail, before the official poll starts. This is very critical step and this should be emphasized during training.

4.5. The Presiding Officers shall mention the names of the Polling agents and the candidates (and their party affiliations), whom they represent and also obtain their signatures on the completion of mock poll on the certificate.

4.6. Where a micro-observer has been appointed at any polling stations, he should also participate in all the proceeding of the mock poll and his signature should also be obtained on the mock poll certificate. Further, these proceedings should be videographed wherever videography arrangement has been made at a polling station.

4.7. The Returning Officer through the Sector Officers and using the communication link with the polling station/ mobile teams, shall track the conduct or otherwise of mock poll, and ascertain the mock poll status. Non-confirmation of mock poll could be indicative of non-commencement of poll and in that case the Returning Officer shall make immediate intervention to sort out the problem.

4.8. The polling stations not having the presence of agents of the candidates of recognized parties and where the mock poll had to be conducted in the absence of agents or with only the polling agent of only one candidate shall merit focused attention of the election machinery. Interventions such as deployment of micro-observers, deployment of video cameras (if not already done), frequent visits by sector officers and other senior officers should be ensured in such cases.

4.9. Mock Poll in case of replacement of EVM - If any defect arises in the Ballot Unit (BU) or Control Unit (CU) of the EVM during poll process, the entire set of EVM (both BU & CU) should be replaced by new set of EVM (BU & CU), a mock poll should be conducted on the new set of EVM (both BU & CU) before it is put to use. However, in this case, it would be sufficient to cast at least one vote each for each of the candidates. A new mock poll certificate

should be recorded in such a case. A note should also be added in such cases, in the original mock poll certificate that the original Control Unit was replaced, and that mock poll was conducted on the new Control Unit before putting it to use. The exact time of replacement should also be mentioned in the note.

4.10. Recording of Poll Start and Poll End Date and Time - It has been brought to the notice of the Commission that in the elections where post – 2006 make EVMs were used, in some cases, the date and time of start and end of poll displayed in the Control Unit of EVM during the process of counting of votes did not match with Indian Standard Time of start and end of poll leading to confusion in the minds of stakeholders. This can only happen if the date and time displayed in the Control Unit are not checked at the time of Candidate Set procedure and also at the time of poll. To remove such confusion in future, the Commission has decided to issue the following instruction in this regard:-

4.11. The display of date and time in the Control Unit of the EVM shall be checked each time the power switch of Control Unit is switched on during the process of First Level Checking of EVM and again at the time of Preparation of EVM by Returning Officer. In case any difference from Indian Standard Time is noticed the clock shall be recalibrated by the engineers of the BEL/ECIL.

4.12. The Presiding Officer at the end of Mock Poll at the polling station shall invariably check and note the date and time shown in the display of the Control Unit and also the actual date and time at that point of time as well as any discrepancy between the two, if any, in the Mock Poll certificate (Annexure-8) and also in Presiding Officers' Diary.

4.13. At the time of closure of poll the presiding officer shall make a note of the Poll end date and time displayed on the CU in the presiding officer's diary.

4.14. During the process of counting of votes, a copy of the Mock Poll certificate prepared by the Presiding Officer shall be brought to the counting table with the Control Unit pertaining to that polling station.

5. Standing Instructions to Zonal/Sector/Area Officers regarding EVMs – The following instructions shall be complied with for ensuring safe movement of EVMs by Zonal/Sector/Area Magistrates. Following category of EVMs move on poll day with either poll party or Sector/Zonal/Area Magistrate:-

5.1. Category “A” -Polled EVMs – Those EVMs in which votes in respect of all polling station is registered and closed at the end of poll after following due procedure.

5.2. Category “B” - Defective polled EVMs – which become defective after some votes are recorded in it.

5.3. Category – “C” - Defective unpolled EVMs – which become defective before commencement of poll and are replaced.

5.4. Category – “D” - Unused EVMs – EVMs which are with Sector/Zonal/Area Magistrate, and are not used in actual poll.

5.5. Zonal Magistrates and Area Officers who are given EVMs from reserve stock will maintain a register where the particulars of Balloting Units (BU) and Control Units (CU) issues are mentioned and a receipt shall be obtained for the machines given to them. Such officers should also maintain the accounts of EVMs replaced in the register maintained by them for this purpose duly signed by the concerned Presiding Officers, indicating time of replacement.

5.6. Zonal/Sector/Area Officers should visit every polling station in their jurisdiction as many times as possible on the poll day and check working of EVMs and other things.

5.7. EVMs of category ‘A’ are stored in a Strong Room as per procedure.

5.8. EVMs of category ‘B’ are also stored separately with the EVMs of category ‘A’ in a Strong Room. In respect of this category of EVMs the Sector/Zonal/Area Magistrate shall keep a record of it and furnish a certificate to the effect while returning the EVMs of category ‘D’ on the next day of poll. The information furnished by them shall be tallied with Presiding Officer’s diary by the Returning Officer and the Observer before commencement of counting of votes.

5.9. EVMs of category ‘C’ are stored separately in a separate room other than the strong room. The sticker of defective unpolled EVMs should be pasted on the carrying cases of such category of Ballot Unit and Control Unit, for technical evaluation of the same by the manufacturer.

5.10. EVMs of category ‘D’ are also stored separately in a separate room, other than the strong room, where polled EVMs are kept, by Sector/Zonal/Area Magistrate. The sticker of unused EVMs should be pasted on the carrying cases of such category of Ballot Unit and Control Unit.

5.11. The store where the EVMs of category ‘C’ and ‘D’ will be kept is to be decided in advance and intimated to the political parties/candidates. It should not be in the vicinity of the collection and the counting center so as to arouse any suspicion. This category of EVMs should also not be collected on the day of poll rather it should be collected on the next day of

poll from the concerned Zonal/Sector/Area Officers. On the day of poll these category of EVMs should be in the personal custody of Zonal/Sector/Area Officers, as these are unused EVMs. Also proper documentation of such and other unused EVMs are to be made before they are transported to the store by the Zonal/Sector/Area Magistrate themselves

6. Additional Instructions on Use of EVMs in Polling Stations - In order to ensure that the conduct of the Presiding Officer and other polling staff in no way gives scope for any complaint the Commission has issued the following instruction for the strict adherence:-

6.1. The D.E.O shall supply a printed sample of EVM ballot unit pasted on a cardboard (real size) to all the presiding officers along with other polling materials at the time of dispatch. While printing such model ballot care shall be taken to ensure that only dummy name and dummy symbols that are not in use, are used and not any real names or symbols. It shall be printed in color so that 'blue button' 'green light' and 'red light' etc are clearly represented.

6.2. Whenever any voter asks for help or expresses inability to vote using EVM, the presiding officer can explain to the voter the voting process using the cardboard model of the EVM ballot in such a manner that the voter is able to understand. This shall be done outside the voting compartment only in the presence of polling agents and never inside the voting compartment.

6.3. The Presiding Officer or other polling staff shall not frequent the voting compartment as that may give scope for complaints.

6.4. In order to ensure that no voter has committed any mischief by pasting any paper, tapes etc., on the symbol/ names / ballot button, the presiding officer may from time to time make an inspection of ballot unit (BU)- but he should make it a point to do so in the immediate presence of polling agents when there is no voter inside the voting compartment.

6.5. Any complaint about the conduct of the polling staff at the polling station shall be taken seriously and properly enquired. The Observers are being instructed to take serious note of such complaints and conduct or cause enquiry into such allegations and submit reports to the Commission.

6.6. All the CUs/ BUs allotted to Polling Stations as above as well as the reserve machines shall be kept in the strong room in the presence of candidates/ agents. They can also be allowed to affix their seal on the lock of the strong room.

7. Instructions to be followed at the time of dispersal of EVMs –

7.1. When the EVMs are taken out of the strong room for dispatch the usual precaution of informing the date and time of opening of strong room in writing to the candidates/ agents shall be followed.

7.2. At the time of dispatch the Presiding Officers shall be advised to compare the machine number inscribed on the metal label and the adhesive sticker and also verify the PS no indicated on the sticker compared with PS no mentioned in the address tag before accepting the EVM. Discrepancy if any shall be brought to the notice of the officer in charge of dispatch arrangement and be reconciled.

7.3. The candidates may be advised to share the machine number of the EVM (both CU/ BU) allotted to the specific PS with their polling agent/ agents appointed by them so that they are in a position to inspect the EVM for their satisfaction before the commencement of mock poll on the poll day. The Presiding Officers shall be advised to show the machine number to the agents present before the commencement of the mock poll. It is relevant to note that as per the existing instructions the presiding officer is supposed to mention the number of CU/ CUs used; serial numbers of CU/CUs used; numbers of BU/BUs used and serial numbers of BU/BUs used at the polling station in the Presiding Officer's Diary (refer: Chapter XXVIII, Para 1 of Handbook for Presiding Officers- At elections where electronic voting machines are used, 2004). This instruction shall be scrupulously followed.

8. Replacement of EVMs during Poll –

8.1. In case of replacement of CU or BU due to reason at any polling station the sector officer or any authorized officer who effects such replacement shall prepare a special report indicating the machine number of the existing CU/BU and new CU /BU separately. The officer shall also mention in the special report, the reason of such replacement and votes polled in the replaced machine at that point of time of replacement. One copy of the special report should be left with the Presiding Officer while retaining a copy to be handed over to the R.O.

8.2. In case replacement of EVMs becomes necessary the entire set including the CU and all the BUs shall be replaced. Before starting poll in the new EVM a mock poll will be done according to the instructions for mock poll at the beginning of the poll and a mock poll certificate will be given by the presiding officer separately for this EVM.

8.3. In case of replacement the Unique ID number of the CU and BUs which have been used after replacement should be marked against the concerned polling station in the EVM tracking software.

8.4. Reception of EVMs after Polls - The machines shall be escorted back after the poll is over to the reception centers under proper escort. After all formalities are completed, the EVMs shall be kept in strong room and the room sealed in the presence of the candidates/their agents and Observer.

9. Instructions in case of Re-poll –

9.1. In case of re-poll, the EVM required for re-poll shall be drawn from the reserve list and the CU/BU number shall be informed to the candidates/agents in writing. Care shall be taken to ensure that the address tag on the CU and BU clearly mentions it to be the EVM for use in the re-poll indicating the date and PS no.

9.2. After re-poll the strong room shall be re-opened in the presence of the candidates/ their agents and observer for the storage of the re-pollled EVM. This re-pollled EVM should be placed together with the old EVM which was used earlier in the original poll. A tag ‘Not to be counted’ shall be put prominently on the old EVM and another tag ‘Re-pollled EVM – to be counted’ shall be put on the new re-pollled EVM. RO shall put signature on both the tags.

9.3. In case of re-poll the unique ID number of the CU and BUs used in re-poll should be entered in the EVM tracking software.

10. Instructions relating to Counting –

10.1. General Instructions –

10.1.1. Before starting the counting in the EVM the unique ID number of the CU, the Unique ID number of the Pink Paper Seal and the unique ID number of Green paper seal should be verified from the record and shown to the polling agents.

10.1.2. In Post-2006 EVMs the Poll start date and time and poll end date and time displayed on the CU should be verified from the record and shown to the polling agents.

10.1.3. During counting a close up video recording of the display on the CU should be done at all time so that every thing displayed on the CU including the the votes recorded in favour of each candidate in the CU are recorded on the video.

10.2. Procedure in case the poll start date and time or poll end date and time does not match the record –

10.2.1. In case of any discrepancy in the date and time of start and end of poll displayed in the Control Unit with Indian Standard Time of start and end of poll, the difference will be compared with the date and time noted by Presiding Officer in the mock poll certificate.

10.2.2. If the date and time difference at the time of mock poll does not match with the date and time difference of start and end of poll at the time of counting, the EVM will be kept

aside and the matter will be referred to the Commission for its decision. If on other hand, the difference of date and time at the time of mock poll matches with the difference of date and time of start and end of poll noticed at the time of counting, the discrepancy will be explained to the candidates and their representatives and the votes polled in the EVM will be counted in the usual manner.

10.3. Instructions in case the Presiding officer has not pressed the close button at the end of the poll - The following action be taken during counting of votes, in such circumstances, in the presence of candidates/their authorized agents, under videography: -

10.3.1. In case any Control Unit does not display result due to not-pressing of “Close” button by the Presiding Officer in the polling station at the close of poll, it should be kept back inside its carrying case and then be kept in the Returning Officer’s custody in the counting hall. Counting of votes in other machines should continue as usual.

10.3.2. When counting of votes in other machines is completed, the Returning Officer and Observer should see whether the margin of votes between the first candidate and the runner up is more or less than the votes polled in such machine (s).

10.3.3. In both the cases where the margin of votes is more or less than the total votes polled in that machine (s), the Returning Officer/Counting Supervisor shall press the “Total” button of the Control Unit to see the total votes polled in that machine (s). In case, total votes polled in the machine (s) tallies with the total votes polled mentioned in the Form-17 C, the Returning Officer/Counting Supervisor shall press the “Close” button of the Control Unit (s) so that “Result” button can be pressed for getting result data explaining the entire issue to the candidates and/or their authorised agents and recording a proceeding in this behalf with the signatures of the candidates/their authorised agents. In such a case, the Returning Officer and Observer should send a detailed report to the Commission in the format mentioned at Annexure-9.

10.3.4. In case, total votes polled in the machine(s) does not tally with the total votes polled mentioned in the Form-17 C, the matter should be referred by the Returning Officer to the Commission for its decision and action may be taken as per the direction of the Commission. In such a case, the Returning Officer and Observer should also send a detailed report to the Commission in the format mentioned at Annexure-10, where the margin of vote between the candidates having highest vote and the runner up is more than the votes polled in the Control Unit in question, and in Annexure-11, where such margin is less.

10.4. After completion of counting, all such Control Units whether result has been retrieved from it or not, the Control Unit should be kept back inside its carrying case. The carrying cases should then be sealed once again. The Returning Officer and Observer should put their signatures on the seal. All candidates and their election agents should also be allowed to put their signature on the seal. The Control Unit should be then kept in the strong room (s).

10.5. Instructions in case of EVMs malfunctioning at the time of Counting - The following action to be taken in case of malfunctioning of EVM during counting of votes during elections: -

10.5.1. In case any Control Unit does not display result, it should be kept back inside its carrying case and then be kept in the Returning Officer's custody in the counting hall. Counting of votes in other machines should continue as usual.

10.5.2. When counting of votes in other machines is completed, the Returning Officer and Observer should see whether the margin of votes between the first candidate and the runner up is more or less than the votes polled in the malfunctioned machine (s).

10.5.3. In both the cases where the margin of votes is more or less than the total votes polled in the malfunctioning machine (s), the Returning Officer should try to retrieve the result from this machine, with the help of engineers of BEL/ECIL, using Auxiliary Display Unit (ADU) in the presence of candidates or their election agents. If the result can be retrieved by using an ADU, the result of the election can be declared accordingly. In such a case, the Returning Officer and Observer should send a detailed report to the Commission in the format mentioned at Annexure-12.

10.5.4. In case it is not possible to retrieve the result from the malfunctioning machine even by using ADU, then the Returning Officer should try to retrieve the result from the machine by taking a print out of the result with the help of engineers of BEL/ECIL. If the result can be retrieved by using a printer, the result of the election can be declared accordingly. In such a case, also the Returning Officer and Observer should also send a detailed report to the Commission in the format mentioned at Annexure-12.

10.5.5. If the result from the malfunctioned machine can not be retrieved even by using printer, the matter should be referred by the Returning Officer to the Commission for its decision and action may be taken as per the direction of the Commission. In such a case, the Returning Officer and Observer should also send a detailed report to the Commission in the format mentioned at Annexure-13, where the margin of vote between the candidates having highest vote and the runner up is more than the votes polled in the malfunctioned EVM, and in Annexure-14, where such margin is less. In no case the machine should be

opened, or its outer or inner seals disturbed in any manner. There should be no attempt to repair the machine. Replacement of any parts of the EVM in the field level is strictly forbidden.

10.5.6. After completion of counting, all the Control Units whether result has been retrieved from it or not should be kept back inside their respective carrying cases. The carrying cases should then be sealed once again. The Returning Officer and Observer should put their signatures on the seal. All candidates and their election agents should also be allowed to put their signature on the seal. The Control Unit should be then kept in the strong room (s).

Yours faithfully,

(K N BHAR)
SECRETARY

Annexure – 1

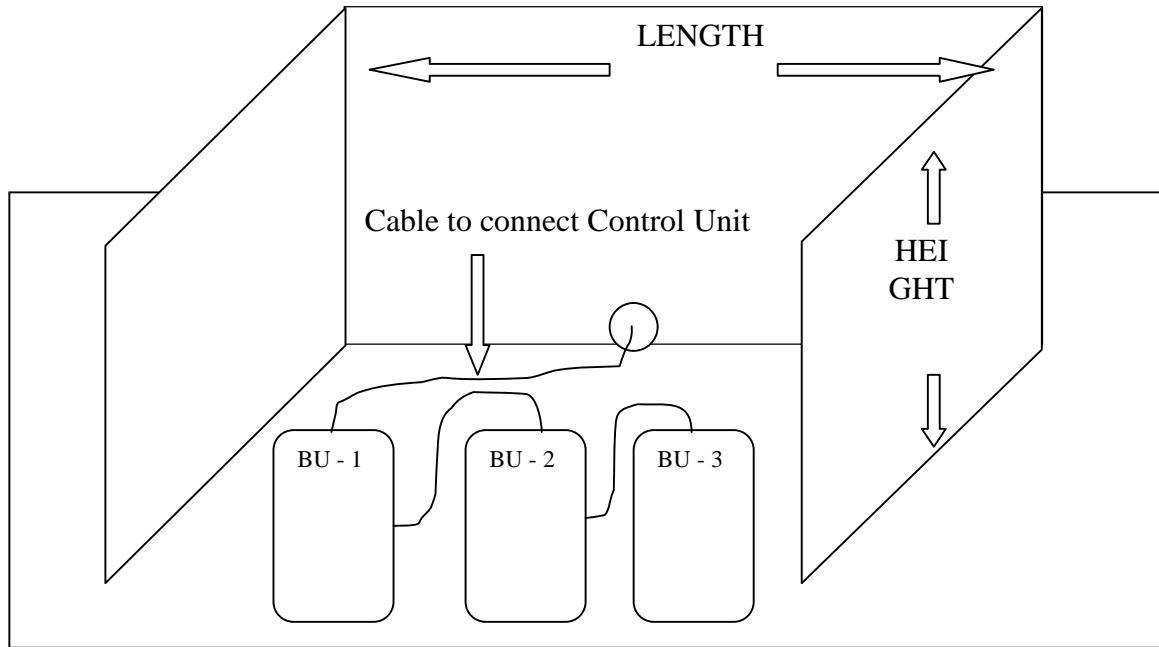

NOTE: Ballot Unit placed as 'BU-1' will contain the names of candidates 1 –16;

Ballot Unit placed as 'BU-2' will contain the names of candidates 17 –32; and so on..

Annexure-2

(Register for Preparation of EVMs)

Name of State/UT:

Name of District:

Name of Assembly/Parliamentary Constituency:

Address of Preparation of EVM hall:

Date:

| S.No. | Name of candidate | Name of representative of candidates with party affiliation, if any | Identity document No. with date | Signature of candidates/ His representative | Remarks, if any. |
|-------|-------------------|---|---------------------------------|---|------------------|
| | | | | | |
| | | | | | |
| | | | | | |
| | | | | | |
| | | | | | |

Note: If a candidate or his representative is absent the proof of due service of notice to the candidate should be pasted in the register.

(Name and signature of engineers of BEL/ECIL with ID No.)

(Name, designation, signature of officers nominated by District Election Officer)

Annexure-3

(Certification of EVMs by BEL/ECIL)

Name of State/UT:

Name of District:

Name of Assembly/Parliamentary Constituency:

Address of hall:

Date:

It is certified that tests prescribed by BEL/ECIL to ascertain that all components are original were carried out on the Ballot Unit listed below on..... (date). On the basis of these tests it is certified that all components of the Ballot Unit listed below are original.

BU Identification No.

| |
|--|
| |
| |
| |
| |

(Name & signature of BEL/ECIL engineers with ID No.)

Annexure-5

(Mock Poll certification during Preparation of EVMs)

Date:.....

Name of State/UT:

Name of District:

Name of Assembly/Parliamentary Constituency:

Address of hall:

It is certified that a printout of the result of mock poll as well as a sequential print out of every vote polled during the mock poll has been taken out from EVMs picked up by me. There are no discrepancies between the votes polled during the mock poll and result in the print out.

| S.No. | Name of candidate | Name of representative of candidate with party affiliation, if any | Identity document No. with date | Signature of candidate/his representative | Remarks, if any. |
|-------|-------------------|--|---------------------------------|---|------------------|
| | | | | | |
| | | | | | |
| | | | | | |
| | | | | | |

Annexure-6

(Register for Sealing of Ballot Unit of EVMs using Pink Paper Seal)

Name of State/UT:

Name of District:

Address of FLC hall:

Date:

It is certified that the sealing of the Ballot Units using Pink Paper Seals has been done in my presence. I have put my signature on the Pink Paper Seals after sealing of the Ballot Units and I am satisfied with the sealing of the Ballot Units.

| Sl.No. | Unique ID No. of Ballot Unit | Pink Paper Seal Number |
|--------|------------------------------|------------------------|
| | | |
| | | |
| | | |

| S.No | Name of candidate | Name of political party with party affiliation, if any | Identity document No. with date | Signature of candidate/ his representative |
|------|-------------------|--|---------------------------------|--|
| | | | | |
| | | | | |
| | | | | |
| | | | | |
| | | | | |

Annexure - 7

Mock Poll Certificate

This is certified that I Presiding Officer at the Polling Station No -----of ----
----- Assembly Constituency (or the -----Assembly segment under -----
-----Parliamentary Constituency) conducted the mock poll at ---- AM today, the poll day i.e. -----
---, following scrupulously all the instructions issued by the Election Commission of India.

A total of ----- votes were polled in the mock poll and after the mock poll I have carefully cleared the memory of the mock poll and the total votes polled showed '0' after clearing the memory.

A. At the time of mock poll the following of polling agents representing the candidates whose names mentioned against the names of such agents were present and I have obtained their signatures.

Sl.No. Name of Polling Agent Name of Party Name of candidates Signature of Polling Agent

- 1.
- 2.
- 3.
- 4.
- 5.

B. At the time of mock poll the agent of only one contesting candidate was present. After waiting for fifteen more minutes, I conducted the mock poll along with other polling staff at ----- I have mentioned before the name of the agent present at the time of mock poll including the name of the candidate whom he represented.

(In case, no agent was present it shall be mentioned “ No Polling agent was present at the time of mock poll”)

| | | |
|-------------------|---|------------------------|
| Name of the agent | Name of the Candidate (with Party affiliation) | Signature of the agent |
|-------------------|---|------------------------|

Signature of micro-observer (if posted at the polling station)

Date:
Time:

Name & Signature
of the Presiding Officer
Polling Station No.....

Annexure – 8
Mock Poll Certificate

This is certified that I Presiding Officer at the Polling Station No -----of ----
----- Assembly Constituency conducted the mock poll at ---- AM today, the
poll day i.e. -----, following scrupulously all the instructions issued by the Election Commission
of India.

A total of ----- votes were polled in the mock poll and after the mock poll I have
carefully cleared the memory of the mock poll and the total votes polled showed '0' after clearing
the memory.

At the end of Mock Poll, I checked the date and time as shown in the display of the Control
Unit (Unique ID No. of CU.....).

The CU showed the date and time as:

Date..... Time.....

The actual date and time at that point of time was:

Date..... Time.....

Discrepancy between the above date and time, if any:.....

The above mentioned process has been performed in the presence of the following agents of
the political parties/candidates whose signatures are obtained below :-

| <u>Sl.No.</u> | <u>Name of Polling Agent</u> | <u>Name of Party</u> | <u>Signature of Polling Agent</u> |
|----------------------|-------------------------------------|-----------------------------|--|
|----------------------|-------------------------------------|-----------------------------|--|

- 1.
- 2.
- 3.
- 4.
- 5.

Date:
Time:

Name & Signature of the Presiding Officer
Polling Station No.....

Annexure-9

(Report on getting result data from Control Unit whose CLOSE button was not pressed by
Presiding Officer at the end of poll)

Name of State/UT:

Name of District:

Name of election:

Number & Name of Assembly/Parliamentary Constituency:

Date of Counting:

It is certified that the result has been obtained from the following Control Unit(s) after pressing CLOSE button in the presence of the contesting candidates/their counting agents. The result of the election has been declared taking into consideration the result from this machine as well.

| Sl.No. | Polling Station No. | Unique ID No. of Control Unit | Detailed Report | No. of votes polled in the Control Unit as per Form 17C |
|---------------|----------------------------|--------------------------------------|------------------------|--|
| | | | | |
| | | | | |
| | | | | |

Final statement showing votes polled by the winning and runner up candidates

| S.No. | Name of candidate | Party affiliation, if any | Votes polled |
|--------------|--------------------------|----------------------------------|---------------------|
| | | | |
| | | | |

(Name & Signature of Returning Officer)

(Name & Signature of Observer)

Annexure-10

(Report on discrepancy in total votes shown in the Control Unit whose CLOSE button was not pressed by Presiding Officer at the end of poll and as mentioned in Form 17-C)

Name of State/UT:

Name of District:

Name of election:

Number & Name of Assembly/Parliamentary Constituency:

Date of Counting:

It is certified that the discrepancy has been noticed in the total votes polled in the following Control Unit(s), after pressing TOTAL button of the Control Unit and comparing it with the total votes polled mentioned in Form 17-C.

| Sl.No. | Polling Station No. | Unique ID No. of Control Unit | No. of votes polled displayed by Control Unit on pressing TOTAL button | No. of votes polled in the Control Unit as per Form 17C | Remarks |
|---------------|----------------------------|--------------------------------------|---|--|----------------|
| | | | | | |
| | | | | | |
| | | | | | |

Final statement showing votes polled by the winning and runner up candidates

| S.No. | Name of candidate | Party affiliation, if any | Votes polled |
|--------------|--------------------------|----------------------------------|---------------------|
| | | | |
| | | | |

As the margin of votes between the candidate having highest votes and the runner up is more than the votes polled mentioned in the Form 17C relating to the Control Unit(s) mentioned above, the matter is being referred to the Commission for permission to set aside the votes polled in the said Control Units (s) and to declare the result.

(Name & Signature of Returning Officer)

(Name & Signature of Observer)

Annexure-11

(Report on discrepancy in total votes shown in the Control Unit whose CLOSE button was not pressed by Presiding Officer at the end of poll and as mentioned in Form 17-C)

Name of State/UT:

Name of District:

Name of election:

Number & Name of Assembly/Parliamentary Constituency:

Date of Counting:

It is certified that the discrepancy has been noticed in the total votes polled in the following Control Unit(s), after pressing TOTAL button of the Control Unit and comparing it with the total votes polled mentioned in Form 17-C.

| Sl.No. | Polling Station No. | Unique ID No. of Control Unit | No. of votes polled displayed by Control Unit on pressing TOTAL button | No. of votes polled in the Control Unit as per Form 17C | Remarks |
|---------------|----------------------------|--------------------------------------|---|--|----------------|
| | | | | | |
| | | | | | |
| | | | | | |

As the margin of votes between the candidate having highest votes and the runner up is less than the votes polled mentioned in the Form 17C relating to the Control Unit(s) mentioned above, the matter is being referred to the Commission for appropriate orders.

Statement showing votes polled by the candidates having highest votes and runner up

| S.No. | Name of candidate | Party affiliation, if any | Votes polled |
|--------------|--------------------------|----------------------------------|---------------------|
| | | | |
| | | | |

(Name & Signature of Returning Officer)

(Name & Signature of Observer)

Annexure-12

(Report on retrieving result data from Control Unit by using Auxiliary Display Unit and Printer)

Name of State/UT:

Name of District:

Name of election:

Number & Name of Assembly/Parliamentary Constituency:

Date of Counting:

It is certified that the result has been retrieved from the following malfunctioned Control Unit (s) by using Auxiliary Display Unit/Printer in the presence of the contesting candidates/their counting agents. The result of the election has been declared taking into consideration the result from this machine as well.

| Sl.No. | Unique ID No. of Control Unit | Detailed Report | No. of votes polled in the malfunctioned Control Unit as per Form 17C |
|--------|-------------------------------|-----------------|---|
| | | | |
| | | | |
| | | | |

Final statement showing votes polled by the winning and runner up candidates

| S.No. | Name of candidate | Party affiliation, if any | Votes polled |
|-------|-------------------|---------------------------|--------------|
| | | | |
| | | | |

(Name & Signature of Returning Officer)

(Name & Signature of Observer)

Annexure-13

(Report on non-retrieving result from Control Unit by using Auxiliary Display Unit and Printer)

Name of State/UT:

Name of District:

Name of election:

Number & Name of Assembly/Parliamentary Constituency:

Date of Counting:

It is certified that the result could not be retrieved from the following malfunctioned Control Unit (s) by using Auxiliary Display Unit and Printer.

| Sl.No. | Unique ID No. of Control Unit | Detailed Report | No. of votes polled in the malfunctioned Control Unit as per Form 17C |
|---------------|--------------------------------------|------------------------|--|
| | | | |
| | | | |
| | | | |

Final statement showing votes polled by the winning and runner up candidates

| S.No. | Name of candidate | Party affiliation, if any | Votes polled |
|--------------|--------------------------|----------------------------------|---------------------|
| | | | |
| | | | |

As the margin of votes between the candidate having highest votes and the runner up is more than the votes polled in the malfunctioned Control Unit (s) mentioned above, the matter is being referred to the Commission for permission to set aside the votes polled in the said Control Units (s) and to declare the result.

(Name & Signature of Returning Officer)

(Name & Signature of Observer)

Annexure-14

(Report on non-retrieving result from Control Unit by using Auxiliary Display Unit and Printer)

Name of State/UT:

Name of District:

Name of election:

Number & Name of Assembly/Parliamentary Constituency:

Date of Counting:

It is certified that the result could not be retrieved from the following malfunctioned Control Unit (s) by using Auxiliary Display Unit and Printer.

| Sl.No. | Unique ID No. of Control Unit | Detailed Report | No. of votes polled in the malfunctioned Control Unit as per Form 17C |
|---------------|--------------------------------------|------------------------|--|
| | | | |
| | | | |
| | | | |

As the margin of votes between the candidate having highest votes and the runner up is less than the votes polled in the malfunctioned Control Unit (s) mentioned above, the matter is being referred to the Commission for appropriate orders.

Statement showing votes polled by the candidates having highest votes and runner up

| S.No. | Name of candidate | Party affiliation, if any | Votes polled |
|--------------|--------------------------|----------------------------------|---------------------|
| | | | |
| | | | |

(Name & Signature of Returning Officer)

(Name & Signature of Observer)